



# STANDBY GENERATORS

\*English/French Model

# 17 kW

## Air-Cooled Gas Engine Generator Sets

**Continuous Standby Power Rating**  
Model 05613 (Steel - Bisque) - 17 kW 60Hz

### INCLUDES:

- True Power® Electrical Technology
- Two Line LCD Digital Controller
- Automatic Transfer Switch with Built-In Priority Load Center
- Electronic Governor
- Pre-wired External Connection Box
- External Main Circuit Breaker, System Status & Maintenance Interval LED's and GFCI Duplex Outlet
- Flexible Fuel Line Connector
- Composite Mounting Pad
- Pre-wired conduits
- Natural Gas or LP Gas Operation
- UL 2200 Listed
- English/French Digital Display, Warning Labels and Literature



## QUIET TEST™

## FEATURES

- **INNOVATIVE DESIGN & PROTOTYPE TESTING** are key components of GENERAC'S success in "IMPROVING POWER BY DESIGN." But it doesn't stop there. Total commitment to component testing, reliability testing, environmental testing, destruction and life testing, plus testing to applicable CSA, NEMA, EGSA, and other standards, allows you to choose GENERAC POWER SYSTEMS with the confidence that these systems will provide superior performance.
- **TRUE POWER® ELECTRICAL TECHNOLOGY:** Superior harmonics and sine wave form produce less than 5% Total Harmonic Distortion for utility quality power. This allows confident operation of sensitive electronic equipment and micro-chip based appliances, such as variable speed HVAC.
- **TEST CRITERIA:**
  - ✓ PROTOTYPE TESTED
  - ✓ SYSTEM TORSIONAL TESTED
  - ✓ NEMA MG1-22 EVALUATION
  - ✓ MOTOR STARTING ABILITY
- **SOLID-STATE, FREQUENCY COMPENSATED VOLTAGE REGULATION.** This state-of-the-art power maximizing regulation system is standard on all Generac models. It provides optimized FAST RESPONSE to changing load conditions and MAXIMUM MOTOR STARTING CAPABILITY by electronically torque-matching the surge loads to the engine.
- **SINGLE SOURCE SERVICE RESPONSE** from Generac's dealer network provides parts and service know-how for the entire unit, from the engine to the smallest electronic component. You are never on your own when you own a GENERAC POWER SYSTEM.
- **GENERAC TRANSFER SWITCHES.** Long life and reliability are synonymous with GENERAC POWER SYSTEMS. One reason for this confidence is that the GENERAC product line includes its own transfer systems and controls for total system compatibility.



ENGINE	•Generac (OHVI) Design	Maximizes engine “breathing” for increased fuel efficiency. Plateau honed cylinder walls and plasma moly rings help engine run cooler, reducing oil consumption. Because heat is the primary cause of engine wear, the OHVI has a significantly longer life than competitive engines.
	•”Spiny-lok” cast iron cylinder walls	Rigid construction and added durability provide long engine life.
	•Electronic ignition/spark advance	These features combine to assure smooth, quick starting every time.
	•Full pressure lubrication system	Superior lubrication to all vital bearings means better performance, less maintenance and significantly longer engine life. Now featuring a 2 year/200 hour oil change interval.
	•Low oil pressure shutdown system	Superior shutdown protection prevents catastrophic engine damage due to low oil.
GENERATOR	•High temperature shutdown	Prevents damage due to overheating.
	•Revolving field	Allows for smaller, light weight unit that operates 25% more efficiently than a revolving armature generator.
	•Skewed stator	Produces a smooth output waveform for compatibility with electronic equipment.
	•Displaced phase excitation	Maximizes motor starting capability.
	•Automatic voltage regulation	Regulates the output voltage to ±2% prevents damaging voltage spikes.
TRANSFER SWITCH	•UL 2200 Listed	For your safety
	•Fully Automatic	Transfers your vital electrical loads to the energized source of power.
	•Remote Mounting	Mounts near your existing distribution panel for simple, low cost installation.
CONTROLS	•UL Listed	For your safety
	•Manual/Auto/Off switch	Selects the operating mode.
	•Utility voltage sensing	Constantly monitors utility voltage, setpoints 65% dropout, 75% pick-up, of standard voltage.
	•Utility interrupt delay	Prevents nuisance start-ups of the engine, adjustable 10-30 seconds.
	•Engine warm-up	Ensures engine is ready to assume the load, setpoint approximately 10 seconds.
	•Engine cool-down	Allows engine to cool prior to shutdown, setpoint approximately 1 minute.
	•Seven day exerciser	Operates engine to prevent oil seal drying and damage between power outages.
	•Timed Trickle Battery charger	Maintains battery charge level to insure starting.
	•Main Line Circuit Breaker	Protects generator from overload.
UNIT	•Electronic governor	Maintains constant 60 Hz frequency.
	•Weather protective enclosure	Ensures protection against mother nature. Hinged key locking roof panel for security. Lift-out front for easy access to all routine maintenance items. Electrostatically applied textured epoxy paint for added durability.
	•Enclosed critical grade muffler	Quiet, critical grade muffler is mounted inside the unit to prevent injuries.
INSTALLATION SYSTEM	•Small, compact, attractive	Makes for an easy, eye appealing installation.
	•Pre-wired External Connection Box	Easy Installation - Virtually all hardware included, plus step-by-step photographed Installation Guide.
	•1’ Flexible Fuel Line Connector	
	•Composite Mounting Pad	
•Pre-wired conduits		
	•UL Listed wire nuts	

GENERATOR		Model 05613 (17 kW)
Rated Maximum Continuous Power Capacity (LP)		17,000 Watts*
Rated Maximum Continuous Power Capacity (NG)		16,000 Watts*
Rated Voltage		120/240
Rated Maximum Continuous Load Current 240 Volts		70.8 LP/66.6 NG
Total Harmonic Distortion		Less than 5%
Main Line Circuit Breaker		65 Amp
Phase		1
Number of Rotor Poles		2
Rated AC Frequency		60Hz
Power Factor		1
Battery Requirement (not included)		Group 26R 12 Volts and 525 Cold-cranking Amperes Minimum
Unit Weight (lbs./kilos)		455/201.8
Dimensions (L x W x H) inches [mm]		48 x 25 x 29 [1218 x 638 x 732]
Sound output in dB(A) at 23 ft. with generator operating at normal load		66
Sound output in dB(A) at 23 ft. with generator in Whisper-Test™ low speed exercise mode		60
ENGINE		Model 05613 (17 kW)
Type of Engine		GENERAC OHVI V-TWIN
Number of Cylinders		2
Rated Horsepower		32 @ 3,600 rpm
Displacement		992cc
Cylinder Block		Aluminum w/Cast Iron Sleeve
Valve Arrangement		Overhead Valve
Ignition System		Solid-state w/Magneto
Governor System		Electronic
Compression Ratio		9.5:1
Starter		12 Vdc
Oil Capacity Including Filter		Approx. 1.9 Qts./1.8L
Operating RPM		3,600
Fuel Consumption		
Natural Gas	cu.ft./hr.	
	1/2 Load	
	Full Load	183
Liquid Propane	ft <sup>3</sup> /hr (gal/hr)[liters/hr]	261
	1/2 Load	59 (1.61)[6.09]
	Full Load	94 (2.57)[9.73]
Required fuel pressure to generator fuel inlet at all load ranges - 5 to 7 inches of water column for natural gas, 11 to 14 inches of water column for LP gas		
CONTROLS		
2-Line Plain Text LCD Display		Simple user interface for ease of operation
Mode Switch		
-Auto		Automatic Start on Utility failure. 7 day exerciser
-Off		Stops unit. Power is removed. Control and charger still operate.
-Manual/Test (start)		Start with starter control, unit stays on. If utility fails, transfer to load takes place.
Engine Start Sequence		Cyclic cranking: 16 sec. on, 7 rest (90 sec. maximum duration)
Engine Warm-up		10 seconds
Engine Cool-Down		1 minute
Starter Lock-out		Starter cannot re-engage until 5 sec. after engine has stopped.
2.5 Amp Timed Trickle Battery Charger		Standard
Automatic Voltage Regulator w/Overvoltage Protection		Standard
Automatic Low Oil Pressure Shutdown		Standard
Overspeed Shutdown		Standard, 72Hz
High Temperature Shutdown		Standard
Overcrank Protection		Standard
Safety Fuse		Standard

Rating definitions - Standby: Applicable for supplying emergency power for the duration of the utility power outage. No overload capability is available for this rating. (All ratings in accordance with BS5514, ISO3046 and DIN6271). \* Maximum wattage and current are subject to and limited by such factors as fuel Btu content, ambient temperature, altitude, engine power and condition, etc. Maximum power decreases about 3.5 percent for each 1,000 feet above sea level; and also will decrease about 1 percent for each 12° C (10° F) above 15.5° C (60° F).

# Standby Generator - 17 kW

TRANSFER SWITCH & PRIORITY LOAD CENTER		Model 05613 (17 kW)
No. of Poles		2
Current Rating (amps)		100
Voltage Rating (VAC)		250
Utility Voltage Monitor (fixed)		
-Pick-up		75%
-Dropout		65%
Return to Utility		approx. 15 sec.
Exerciser weekly for 12 minutes		Standard
UL Listed		Standard
Dimensions (H x W x D) inches[mm]		25.9 x 12.2 x 6.8 [658 x 308 x 172]
Total of Pre-wired Circuits		16
No. 15A 120V		5
No. 20A 120V		5
No. 20A 240V		1
No. 40A 240V		1
No. 50A 240V		1
Circuit Breaker Protected		
Available RMS Symmetrical Fault Current @ 250 Volts		10,000

## Transfer Switch Features

- Electrically operated, mechanically-held contacts for fast, positive connections.
- Rated for all classes of load, 100% equipment rated, both inductive and resistive.
- 2 pole, 250 VAC contactors.
- 160 millisecond transfer time.
- Dual coil design.
- Main contacts are silver plated or silver alloy to resist welding and sticking.
- NEMA 1 (indoor rated) enclosure is standard on the 100 amp switch.

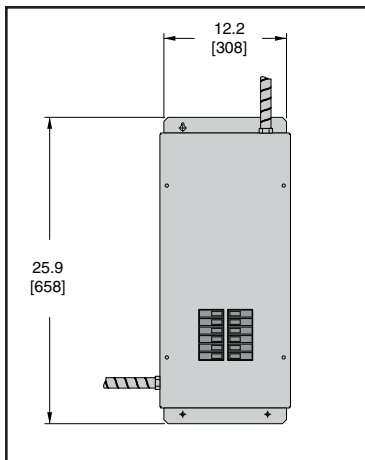

### Terminal Wire Ranges

ATS Rated Amps	Switch Terminal	Neutral Lug/Stud	Ground Lug
100A 2-Pole UL	1 x 1/0-12	1 x 3/8-16 Stud	1 x 2/0-14

